

Features

- LED FIRMLY HELD BY SPACER.
- SUITABLE FOR BACK PANEL ILLUMINATION, CIRCUIT BOARD INDICATOR, LED INDICATOR.
- UL RATING : 94V-0.
- HOUSING MATERIAL: TYPE 66 NYLON.

Notes:

1. All dimensions are in millimeters (inches).
2. Tolerance is $\pm 0.25(0.01")$ unless otherwise noted.

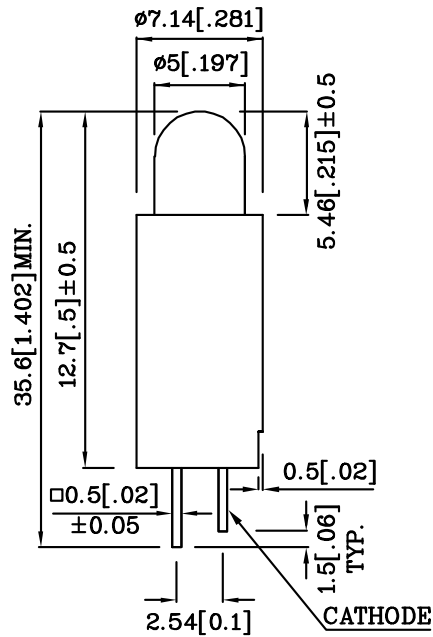

Absolute maximum ratings ($T_A=25^\circ\text{C}$)		UY (GaAsP/GaP)	Unit
Reverse voltage	V_R	5	V
Forward current	I_F	30	mA
Forward current (peak) 1/10Duty cycle 0.1ms pulse width	i_{FS}	140	mA
Power dissipation	P_T	105	mW
Operating temperature	T_A	-40 ~ +85	°C
Storage temperature	T_{stg}	-40 ~ +85	
Lead solder temperature [2mm below package base]	260°C For 5 Seconds		

Operating Characteristics ($T_A=25^\circ\text{C}$)		UY (GaAsP/GaP)	Unit
Forward voltage (typ.) ($I_F=10\text{mA}$)	V_F	1.95	V
Forward voltage (max.) ($I_F=10\text{mA}$)	V_F	2.5	V
Reverse current ($V_R=5\text{V}$)	I_R	10	μA
Wavelength at peak emission ($I_F=10\text{mA}$)	λ_{peak}	590	nm
Wavelength at Dominate emission ($I_F=10\text{mA}$)	λ_D	588	nm
Spectral Line half-width ($I_F=10\text{mA}$)	$\Delta\lambda$	35	nm
Capacitance ($V_F=0\text{V}$, $f=1\text{MHz}$)	C	20	pF

Part Number	Emitting Color	Emitting Material	Lens-color	Luminous Intensity ($I_F=10\text{mA}$) mcd		Wavelength nm λ_P	Viewing Angle $2\theta_{1/2}$
				min.	typ.		
XVN1LUY53D12.7	Yellow	GaAsP/GaP	Yellow Diffused	5	18	590	60°
Published Date : SEP 19,2003 Drawing No : XDSA2917 V2 Checked : B.L.LIU P.1/2							

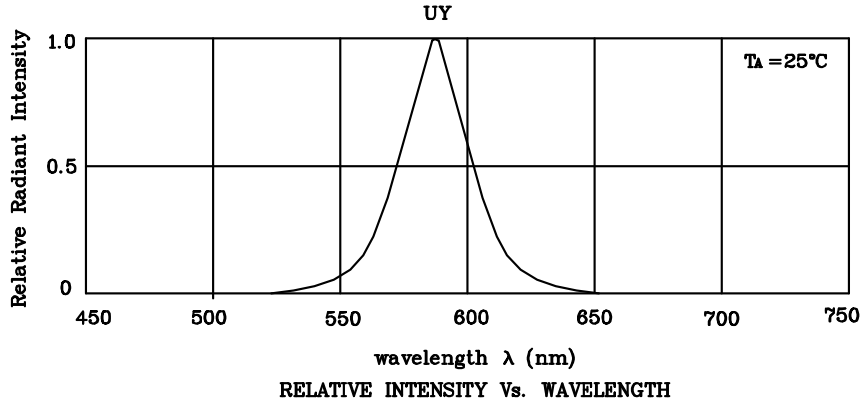

❖ UY

