

### Features

- LED FIRMLY HELD BY SPACER.
- SUITABLE FOR BACK PANEL ILLUMINATION, CIRCUIT BOARD INDICATOR, LED INDICATOR.
- UL RATING : 94V-0.
- HOUSING MATERIAL: TYPE 66 NYLON.

### Notes:

1. All dimensions are in millimeters (inches).
2. Tolerance is  $\pm 0.25(0.01")$  unless otherwise noted.

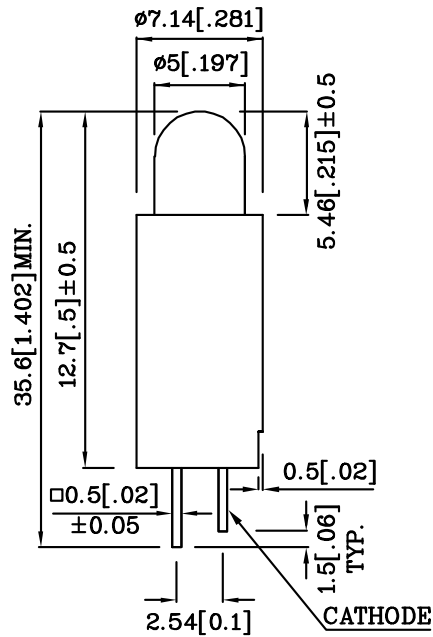

Absolute maximum ratings ( $T_A=25^\circ\text{C}$ )		MR (GaAlAs)	Unit
Reverse voltage	$V_R$	5	V
Forward current	$I_F$	30	mA
Forward current (peak) 1/10Duty cycle 0.1ms pulse width	$i_{FS}$	155	mA
Power dissipation	$P_T$	100	mW
Operating temperature	$T_A$	-40 ~ +85	°C
Storage temperature	$T_{stg}$	-40 ~ +85	
Lead solder temperature [2mm below package base]	260°C For 5 Seconds		

Operating Characteristics ( $T_A=25^\circ\text{C}$ )		MR (GaAlAs)	Unit
Forward voltage (typ.) ( $I_F=20\text{mA}$ )	$V_F$	1.85	V
Forward voltage (max.) ( $I_F=20\text{mA}$ )	$V_F$	2.5	V
Reverse current ( $V_R=5\text{V}$ )	$I_R$	10	$\mu\text{A}$
Wavelength at peak emission ( $I_F=20\text{mA}$ )	$\lambda_{\text{peak}}$	660	nm
Wavelength at Dominate emission ( $I_F=20\text{mA}$ )	$\lambda_D$	640	nm
Spectral Line half- width ( $I_F=20\text{mA}$ )	$\Delta\lambda$	20	nm
Capacitance ( $V_F=0\text{V}$ , $f=1\text{MHz}$ )	$C$	45	pF

Part Number	Emitting Color	Emitting Material	Lens-color	Luminous Intensity ( $I_F=20\text{mA}$ ) mcd		Wavelength nm $\lambda_P$	Viewing Angle $2\theta_{1/2}$
				min.	typ.		
XVN1LMR53D12.7	Red	GaAlAs	Red Diffused	110	295	660	60°
Published Date : SEP 19,2003      Drawing No : XDSA2908      V2      Checked : B.L.LIU      P.1/2							

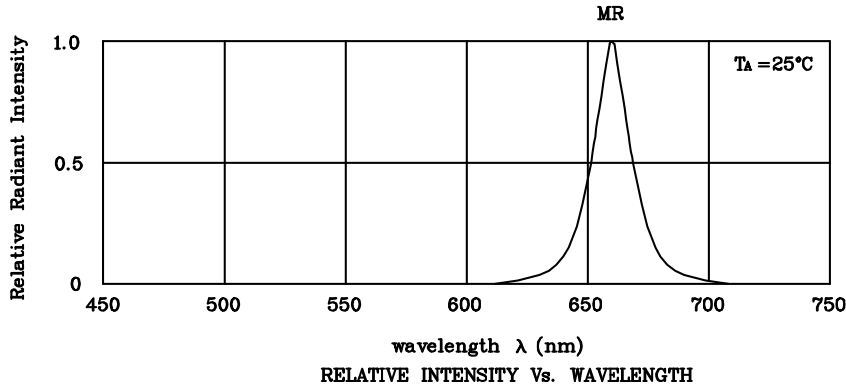

❖ MR

