

Features

- LED FIRMLY HELD BY SPACER.
- SUITABLE FOR BACK PANEL ILLUMINATION, CIRCUIT BOARD INDICATOR, LED INDICATOR.
- UL RATING : 94V-0.
- HOUSING MATERIAL: TYPE 66 NYLON.

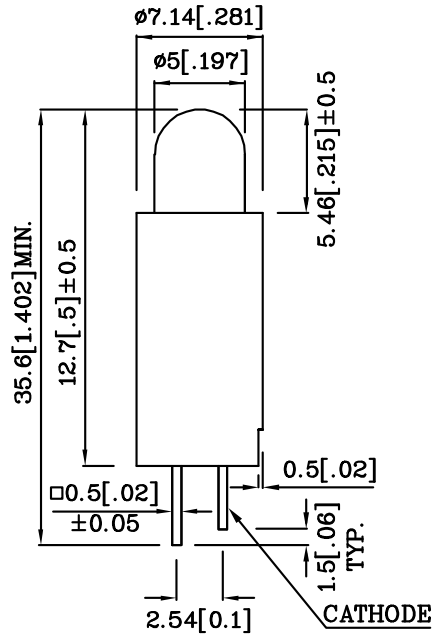

Notes:

1. All dimensions are in millimeters (inches).
2. Tolerance is $\pm 0.25(0.01")$ unless otherwise noted.

| Absolute maximum ratings ($T_A=25^\circ\text{C}$) | | MG (GaP) | Unit |
|---|---------------------|-------------|------|
| Reverse voltage | V_R | 5 | V |
| Forward current | I_F | 25 | mA |
| Forward current (peak) 1/10Duty cycle 0.1ms pulse width | i_{FS} | 140 | mA |
| Power dissipation | P_R | 105 | mW |
| Operating temperature | T_A | -40 ~ +85 | °C |
| Storage temperature | T_{stg} | -40 ~ +85 | |
| Lead solder temperature [2mm below package base] | 260°C For 5 Seconds | | |

| Operating Characteristics ($T_A=25^\circ\text{C}$) | | MG (GaP) | Unit |
|---|-------------------------|-------------|---------------|
| Forward voltage (typ.) ($I_F=20\text{mA}$) | V_F | 2.2 | V |
| Forward voltage (max.) ($I_F=20\text{mA}$) | V_F | 2.5 | V |
| Reverse current ($V_R=5\text{V}$) | I_R | 10 | μA |
| Wavelength at peak emission ($I_F=20\text{mA}$) | λ_{peak} | 565 | nm |
| Wavelength at Dominate emission ($I_F=20\text{mA}$) | λ_D | 568 | nm |
| Spectral Line half- width ($I_F=20\text{mA}$) | $\Delta\lambda$ | 30 | nm |
| Capacitance ($V_F=0\text{V}$, $f=1\text{MHz}$) | C | 15 | pF |

| Part Number | Emitting Color | Emitting Material | Lens-color | Luminous Intensity ($I_F=20\text{mA}$) mcd | | Wavelength nm λ_P | Viewing Angle $2\theta_{1/2}$ |
|---|-------------------|----------------------|----------------|---|------|---------------------------------|-------------------------------------|
| | | | | min. | typ. | | |
| XVN1LMG53D12.7 | Green | GaP | Green Diffused | 18 | 37 | 565 | 60° |
| Published Date : SEP 19,2003 Drawing No : XDSA2914 V2 Checked : B.L.LIU P.1/2 | | | | | | | |

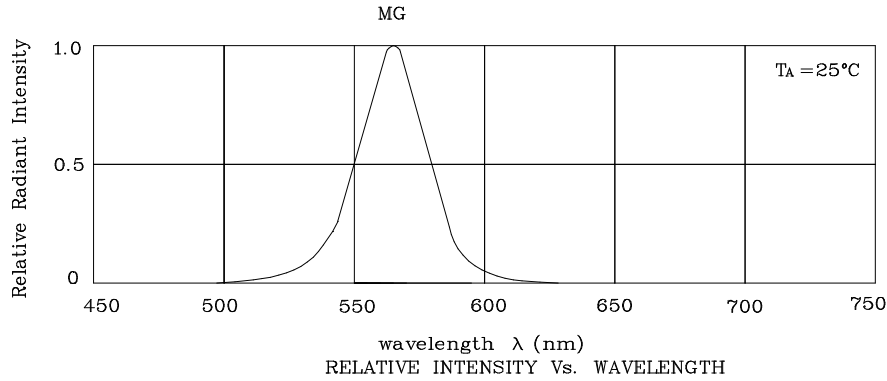

❖ MG

