

Features

- PRE-TRIMMED LEADS FOR PC MOUNTING.
- I.C. COMPATIBLE.
- BLACK CASE ENHANCES CONTRAST RATIO.
- WIDE VIEWING ANGLE.
- HIGH RELIABILITY - LIFE MEASURED IN YEARS.
- UL RATING : 94V-0.
- HOUSING MATERIAL: TYPE 66 NYLON.

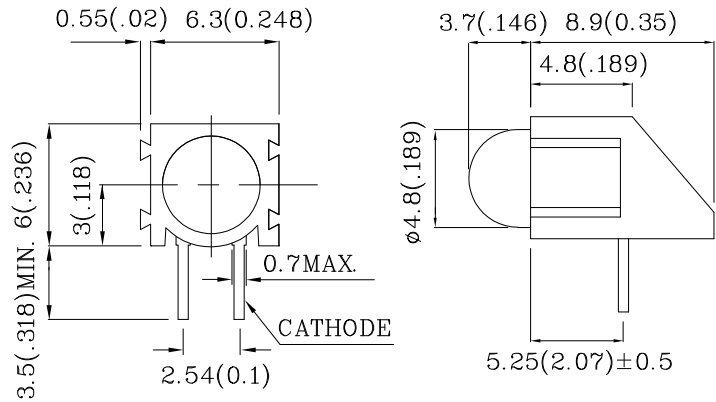

Notes:

1. All dimensions are in millimeters (inches).
2. Tolerance is ± 0.25(0.01") unless otherwise noted.

Absolute maximum ratings (TA=25°C)		UG (GaP)	Unit
Reverse voltage	VR	5	V
Forward current	IF	25	mA
Forward current (peak) 1/10Duty cycle 0.1ms pulse width	iFS	140	mA
Power dissipation	PT	105	mW
Operating temperature	TA	-40 ~ +85	°C
Storage temperature	Tstg	-40 ~ +85	
Lead solder temperature [2mm below package base]	260°C For 3 Seconds		
Lead solder temperature [5mm below package base]	260°C For 5 Seconds		

Operating Characteristics (TA=25°C)		UG (GaP)	Unit
Forward voltage (typ.) (IF=10mA)	VF	2.0	V
Forward voltage (max.) (IF=10mA)	VF	2.5	V
Reverse current (VR=5V)	IR	10	uA
Wavelength at peak emission (IF=10mA)	λ peak	565	nm
Wavelength of Dominant emission (IF=10mA)	λ D	568	nm
Spectral Line half-width (IF=10mA)	Δλ	30	nm
Capacitance (VF=0V, f=1MHz)	C	15	pF

Part Number	Emitting Color	Emitting Material	Lens-color	Luminous Intensity (IF=10mA) mcd		Wavelength nm λ P	Viewing Angle 2 θ 1/2
				min.	typ.		
XVD1LUG48D	Green	GaP	Green Diffused	8	19	565	60°
Published Date : DEC 28,2004 Drawing No : XDSA2844 V3 Checked : B.L.LIU P.1/2							

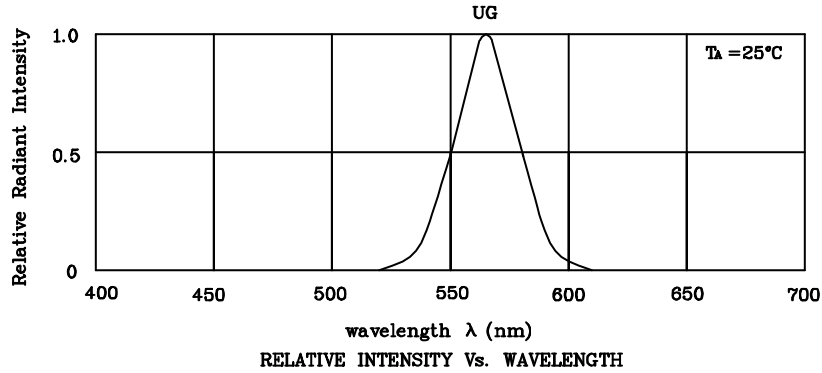

❖ UG

