

**Features**

- PRE-TRIMMED LEADS FOR PC MOUNTING.
- I.C. COMPATIBLE.
- BLACK CASE ENHANCES CONTRAST RATIO.
- WIDE VIEWING ANGLE.
- HIGH RELIABILITY - LIFE MEASURED IN YEARS.
- UL RATING : 94V-0.
- HOUSING MATERIAL: TYPE 66 NYLON.

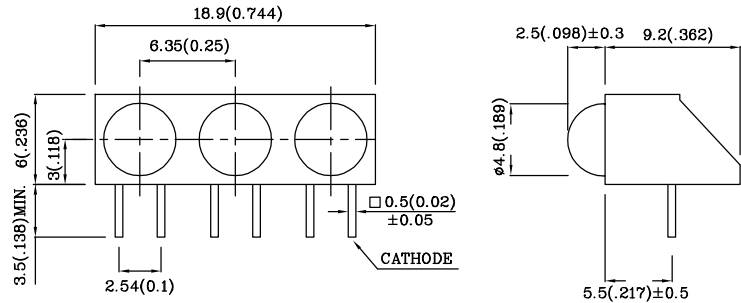

Notes:

1. All dimensions are in millimeters (inches).
2. Tolerance is ± 0.25(0.01") unless otherwise noted.

Absolute maximum ratings (TA=25°C)		MR (GaAlAs)	Unit
Reverse voltage	VR	5	V
Forward current	IF	30	mA
Forward current (peak) 1/10Duty cycle 0.1ms pulse width	iFS	155	mA
Power dissipation	PT	100	mW
Operating temperature	TA	-40 ~ +85	°C
Storage temperature	Tstg	-40 ~ +85	
Lead solder temperature [2mm below package base]	260°C For 5 Seconds		

Operating Characteristics (TA=25°C)		MR (GaAlAs)	Unit
Forward voltage (typ.) (IF=20mA)	VF	1.85	V
Forward voltage (max.) (IF=20mA)	VF	2.5	V
Reverse current (VR=5V)	IR	10	uA
Wavelength at peak emission (IF=20mA)	λ peak	660	nm
Wavelength at Dominate emission (IF=20mA)	λ D	640	nm
Spectral Line half- width (IF=20mA)	Δλ	20	nm
Capacitance (VF=0V, f=1MHz)	C	45	pF

Part Number	Emitting Color	Emitting Material	Lens-color	Luminous Intensity (IF=20mA) mcd		Wavelength nm λ P	Viewing Angle 2 θ 1/2
				min.	typ.		
XVB3LMR48D	Red	GaAlAs	Red Diffused	110	299	660	60°
Published Date : SEP 29,2003      Drawing No :XDSA2832      V2      Checked : B.L.LIU      P.1/2							

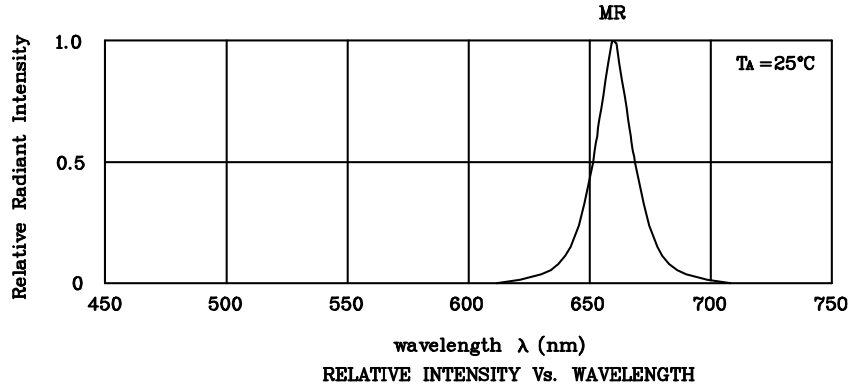

❖ MR

