

Features

- PRE-TRIMMED LEADS FOR PC MOUNTING.
- I.C. COMPATIBLE.
- BLACK CASE ENHANCES CONTRAST RATIO.
- WIDE VIEWING ANGLE.
- HIGH RELIABILITY - LIFE MEASURED IN YEARS.
- UL RATING : 94V-0.
- HOUSING MATERIAL: TYPE 66 NYLON.

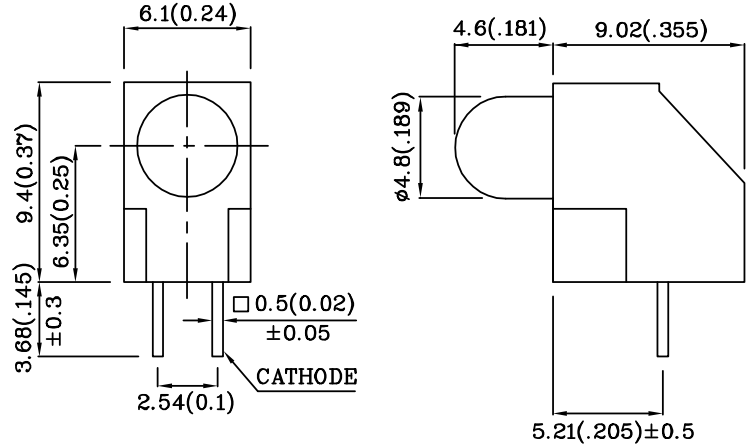

Notes:

1. All dimensions are in millimeters (inches).
2. Tolerance is ± 0.25(0.01") unless otherwise noted.

Absolute maximum ratings (TA=25°C)		UR (GaAsP/GaP)	Unit
Reverse voltage	V _R	5	V
Forward current	I _F	30	mA
Forward current (peak) 1/10Duty cycle 0.1ms pulse width	i _{FS}	160	mA
Power dissipation	P _T	105	mW
Operating temperature	T _A	-40 ~ +85	°C
Storage temperature	T _{stg}	-40 ~ +85	
Lead solder temperature [2mm below package base]	260°C For 5 Seconds		

Operating Characteristics (TA=25°C)		UR (GaAsP/ GaP)	Unit
Forward voltage (typ.) (I _F =10mA)	V _F	1.9	V
Forward voltage (max.) (I _F =10mA)	V _F	2.5	V
Reverse current (V _R =5V)	I _R	10	uA
Wavelength at peak emission (I _F =10mA)	λ peak	627	nm
Wavelength at Dominate emission (I _F =10mA)	λ D	625	nm
Spectral Line half-width (I _F =10mA)	Δλ	45	nm
Capacitance (V _F =0V, f=1MHz)	C	15	pF

Part Number	Emitting Color	Emitting Material	Lens-color	Luminous Intensity (I _F =10mA) mcd		Wavelength nm λ P	Viewing Angle 2 θ 1/2
				min.	typ.		
XPX1LUR48D	Red	GaAsP/GaP	Red Diffused	8	29	627	60°
Published Date : SEP 15,2003 Drawing No : XDSA2854 V2 Checked : B.L.LIU P.1/2							

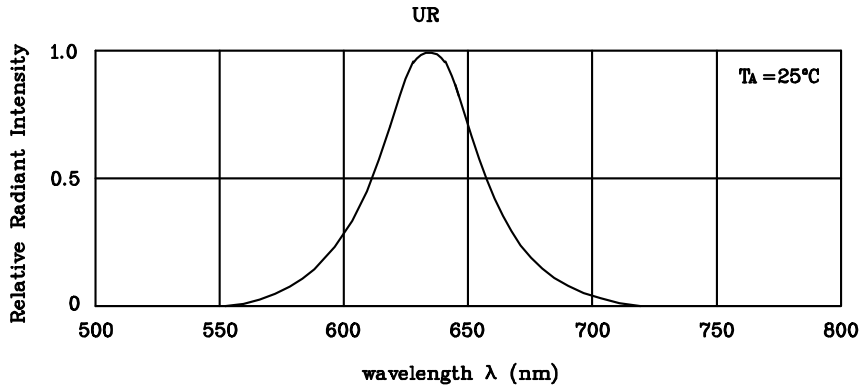

RELATIVE INTENSITY Vs. WAVELENGTH

❖ UR

